

**57<sup>th</sup> Annual Gem and Mineral Display 2025**  
**SATURDAY, 24 MAY 8.00 am to 4.00pm**  
**AT MGLS CLUBROOMS, 1873 LOGAN RD UPPER MT. GRAVATT QLD 4122**

**2025 SCHEDULE**

**NOTES AND CONDITIONS**

Each entry will not be judged against its competitors but will be assessed against an established standard and the resulting score is the measurement of excellence achieved, or how nearly it reaches that standard.

Judging is to the AFLACA Competitor and Judging Manual for Lapidary and Allied Competitions Issue No.8 April 2015 (the Manual), unless otherwise stated in this schedule. The competition committee will be using the guidelines as set out in the Manual except as stated in this schedule. A copy of the Manual is available in the library.

**COMPETITION ENTRY IS FREE**

**Closing date for CLASS 1 TO 29 entries is 12pm on Saturday, 5 April 2025.**

Entries accepted at the clubrooms between 9am and 12pm or by alternate arrangement with the Chief Steward. Postal entries must be received by 5pm on Friday, 4 April 2025. Late entries will be deemed ineligible but may be used for display purposes. If you need to send entries via post, we recommend these be sent at least two (2) weeks prior by express post to ensure entries are received by the due date.

**Closing date for CLASS 30 to 41 entries is 7pm on Tuesday, 20 May 2025.**

Entries accepted at the clubrooms between 4pm and 7pm or by arrangement with the Chief Steward.

Postal entries should be sent by registered mail or express post to:

Chief Steward  
PO Box 150  
MT GRAVATT QLD 4122

**PLEASE ENSURE YOU INCLUDE RETURN POSTAGE AND AN APPROPRIATELY SIZED ENVELOPE**

- No late entries will be accepted for the competition.
- Entries can be collected from 4.15pm on Saturday, 24 May 2025. If you cannot collect your entries on the show day, then you must make alternate arrangements with the Chief Steward. All postal entries must include a return self-addressed envelope/parcel for the return of your entries.
- This is a Level Three Competition. Interstate entries are welcomed. **OTHER CLUBS ARE WELCOME.**
- Entries not complying with conditions may be disqualified by Stewards or placed in the correct class. The Stewards have the right to refuse any entry.
- All possible care will be taken with entries, but the Committee will not be held responsible for loss or damage during transit, display or storage.
- An entry constitutes acceptance of conditions and agreement to comply with them.
- Unsportsmanlike conduct displayed before, during or after the competition may result in disqualification of the entry and the revocation of any awards given.
- Entries by MGLS members that are also members of other clubs will be entered as MGLS members.

Variations to the Manual

1. A pair of earrings or cufflinks are judged as one item (Jewellery classes only)
2. **Limit of 3 (three) entries per person per class**
3. Showcase entry quantities vary from the manual
4. Man-made material can be used as specified in the schedule
5. Class numbers do not correspond to the section numbers in the Manual
6. All metalcraft with sharp or pointed elements must have all sharp/pointed edges padded and be presented in a rigid box ready for postage. This is a requirement of Australia Post and must be met so that entries can be sent for judging. Stewards can refuse entries if packaging requirements are not met.

ENQUIRIES: Please direct any enquiries for the Chief Steward's attention via email to [president@mglslapidary.com.au](mailto:president@mglslapidary.com.au)

**COMPETITION CLASSES**

CS=Craftsmanship, AA=Aesthetic Appeal, Min=minimum, Max=maximum, J&R=Manual, N=Novice, O=Open, NT=Novice Trophy, OT=Open Trophy, PC= President’s Cup, MC=Memorial Trophy, DW=Don Wilkinson Trophy, LS=Laurie & Val Saint Trophy; FT=Novice Faceters Cup, OFT=Open Factors Cup, AGC= All that Glitters Cup

<b>CABOCHONS (Groups 1 &amp; 2)</b>					
Unless specified, all entries can be no longer than 80mm on the longest axis and no shorter than 15mm on the longest axis					
Class	Level	J&R Section	Description	AA or CS	Trophy
<b>PRESIDENTS CUP (MGLS members only)</b>					
1	N	1A	Standard Cabochon – Agate	AA	PC, JC
<b>The MEMORIAL TROPHY (MGLS members only)</b>					
2	O	1B	Fancy Cabochon – set to Open template – Petrified Wood	CS	MC, JC
3	N	1B	Fancy Cabochon – set to Novice template – Petrified Wood	CS	MC, JC
<b>The following are open to all</b>					
4	O	1A	Standard Cabochon – Jasper	CS	OT, JC
5	N	1A	Standard Cabochon – any natural material	CS	NT, JC
6	O	1A	Standard Cabochon – Agate	AA	JC
7	O	1B	Fancy Cabochon – any natural material	CS	JC
8	N	1B	Fancy Cabochon – any natural material	CS	JC
9	O	1B	Fancy Cabochon – any natural material	AA	OT, JC
10	N	1B	Fancy Cabochon – any natural material	AA	NT, JC
11	O	2A	Double Standard Cabochon – any natural material	CS	OT, JC
12	N	2A	Double Standard Cabochon – any natural material	CS	NT, JC

<b>FREEFORMS (Group 3)</b>					
All entries maximum size 90mm on the longest axis, minimum 25mm on longest axis and must not fit through a 30mm round hole.					
Class	Level	J&R Section	Description	AA or CS	Trophy
13	O	3	Freeform – any natural material	AA	DW, JC
14	N	3	Freeform – any natural material	AA	DW, JC

<b>FACET CUTS (Groups 8 – 11)</b>					
All entries should be a minimum 6mm on the longest axis					
Class	Level	J&R Section	Description	Trophy	
15	O	10	Regal Crown Brilliant – Coloured CZ	OT	
16	N	9B	Standard Square Step Cut - coloured Quartz		
17	O	10	Solomon’s Shield #2 – material – coloured Quartz	OFT	
18	N	11	Aphex – material - coloured Quartz	NT, FT, JC	

<b>HAND FABRICATED JEWELLERY (Group 18)</b>					
Class	Level	J&R Section	Description	Trophy	
19	O	18A	Jewellery Hand-Fabricated; not intended to include lapidary, fossil or mineral items	OT, AGC	
20	N	18A	Jewellery Hand-Fabricated; not intended to include lapidary, fossil or mineral items	NT	
21	O	18B	Jewellery Hand-Fabricated; lapidary cut and set by entrant	OT, AGC	
22	N	18B	Jewellery Hand-Fabricated; lapidary cut and set by entrant	NT	
23	O	18D	Jewellery Hand-Fabricated; commercial lapidary item/s set by entrant	AGC	
24	N	18D	Jewellery Hand-Fabricated; commercial lapidary item/s set by entrant	LS	

<b>COMMERCIAL MOUNT JEWELLERY (Group 25)</b>				
Class	Level	&R Section	Description	Trophy
27	O	25	Commercial Mount Jewellery; with lapidary cut & set by entrant; material any natural cabochon; lapidary min 10mm on the longest Axis, Can include but not limited to cufflinks, hairpins, brooches	OT
28	N	25	Commercial Mount Jewellery; with lapidary cut & set by entrant; material any natural cabochon; lapidary min 10mm on the longest Axis, Can include but not limited to cufflinks, hairpins, brooches	NT

<b>GENERAL METALCRAFT (Group 27)</b>				
Class	Level	&R Section	Description	Trophy
29	O	27A	General Metalcraft; not intended to included lapidary; Metalcraft is defined as items that are for general ornamentation and/or service, not jewellery; size to measure between 10mm to 170mm on the longest axis	

*The following classes are to be delivered to the club rooms in person on Tuesday, 20 May 2025 between 4pm and 7pm*

<b>POLISHED FACES (Group 13)</b>					
All entries should be no longer than 120mm and no shorter than 40mm on any dimension through the mid point					
Class	Level	&R Section	Description	AA or CS	Trophy
30	O	13	Polished Face Flat Surface – any material	AA	

<b>NOVELTY GEMCRAFT (Group 17)</b>				
<b>Entries must be accompanied by a label stating title and main materials (Label will not be judged)</b>				
Class	Level	&R Section	Description	Trophy
31	O	17	Novelty gemcraft; Material predominantly lapidary	
32	N	17	Novelty gemcraft; Material predominantly lapidary	
33	O	17	Novelty gemcraft; Adornment to commercial blank eg knives, bottle stoppers, keyrings	
34	N	17	Novelty gemcraft; Adornment to commercial blank eg knives, bottle stoppers, keyrings	

<b>SHOWCASES (Group 30)</b>				
<b>Please note: – Showcase items must be labelled - see page 88 of the manual for information</b>				
Class	Level	&R Section	Description	Trophy
35	O	30A	Showcase; Solo; unlit; 9 cabochons and/or freeform stones; at least 3 different shapes and 4 different materials; may include man made material	
36	N	30A	Showcase; Solo; unlit; 5 cabochons and/or freeform stones; at least 3 different shapes and 4 different materials; may include man made material	
37	O	30A	Showcase; Solo; unlit; 7 pieces of handcrafted jewellery; at least one with and one without lapidary material; may include man made material	
38	N	30A	Showcase; Solo; unlit; 5 pieces of handcrafted jewellery; may include man made material	
39	O	30A	Showcase; Solo; unlit; 5 faceted stones in a small box; any shape or material; may include manmade material	
40	N	30A	Showcase; Solo; unlit; 3 faceted stones in a small box; any shape or material; may include man-made material	

Exhibitors, please note that there are some showcases available for loan from the Stewards

**FOSSICKERS CUP (MGLS members only)**

This will be judged as a Judges Choice.

Entries must be entered as found, however, entries can be partially slabbed but must not be worked

Class	Level	I&R section	Description
41		n/a	Best entry found on a club field trip between 1 May 2024 and 30 April 2025

## CLASS 15: OPEN – Coloured CZ

### Regal Crown Brilliant

Dean Baker - 9th September 2024

#### Facet Data

Pavilion facets	20	Pavilion tiers	4
Girdle facets	4	Girdle tiers	1
Crown facets	25	Crown tiers	6
<b>Total facets</b>	<b>49</b>	<b>Total tiers</b>	<b>11</b>

#### Size Data

L/W	1.000	P/W	0.390
T/W	0.000	C/W	0.196
U/W	0.000	H/W	0.606
V/W*3	0.226	P/C	1.985

#### Design Data

Angles for R.I.	2.16
Size range	8 - 20 mm
Symmetry	4-fold, mirror
Index gear	96
Shape	Octagon

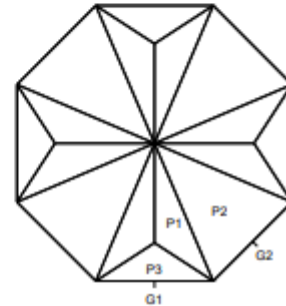
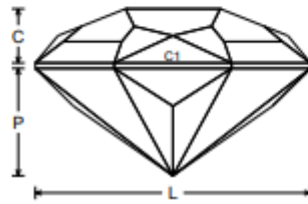
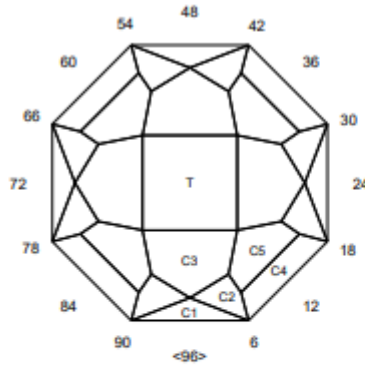

#### Pavilion

P1	35.91	04-20-28-44-52-68-76-92	Cut to PCP
G1	90.00	96-24-48-72	Set stone size and shape, level girdle
P2	37.69	12-36-60-84	Cut to PCP to meet P1, P1
G2	90.00	12-36-60-84	Cut to meet P2
P3	44.65	96-24-48-72	Cut to meet P1, P1 at G1

#### Crown

C1	50.22	96-24-48-72	Set girdle thickness, level girdle
C2	36.26	04-20-28-44-52-68-76-92	Cut to meet C1 at G
C3	21.67	96-24-48-72	Cut to meet C2, C2 at C1
C4	40.25	12-36-60-84	Cut to meet G2
C5	35.08	12-36-60-84	Cut to meet C4
T	0.00	Table	Cut to meet C3, C5

## CLASS 16: NOVICE – Coloured Quartz

### 07.001A Square Emerald 1:2

Steele, Norman W; Seattle F Design, May 78  
S/W=0.585 CC/W=0.293

#### Facet Data

Pavilion facets	24	Pavilion tiers	6
Girdle facets	8	Girdle tiers	2
Crown facets	24+1	Crown tiers	6+1
<b>Total facets</b>	<b>57</b>	<b>Total tiers</b>	<b>15</b>

#### Size Data

L/W	1.000	P/W	0.705
T/W	0.540	C/W	0.129
U/W	0.540	H/W	0.858
V/W <sup>3</sup>	0.372	P/C	5.446

#### Design Data

Angles for R.I.	1.54
Symmetry	4-fold, mirror
Index gear	96

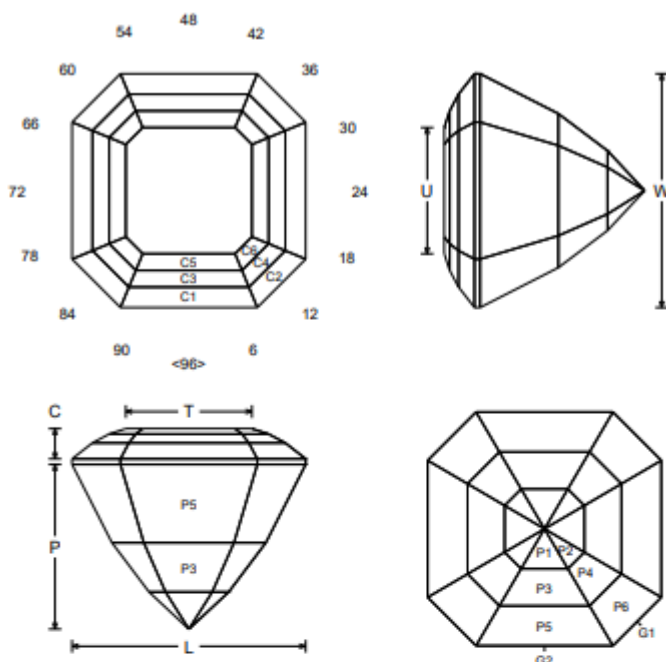

#### Pavilion

P1	43.00	96-24-48-72	Cut PCP
P2	39.75	12-36-60-84	Cut to PCP
G1	90.00	12-36-60-84	Set Size
G2	90.00	96-24-48-72	Set Size
P3	53.00	96-24-48-72	Set size to 1/3
P4	49.80	12-36-60-84	Set size to 1/3
P5	63.00	96-24-48-72	Set size to last 1/3, meet P3, P4
P6	60.26	12-36-60-84	Set size to last 1/3, meet P3, P4

#### Crown

C1	38.00	96-24-48-72	Set Girdle width
C2	38.00	12-36-60-84	Set Girdle width, meet C1
C3	28.00	96-24-48-72	Set size of C1
C4	28.00	12-36-60-84	Set size of C2
C5	18.00	96-24-48-72	Set Size of C3
C6	18.00	12-36-60-84	Set Size of C4
0.00	Table		Set size of C5, C6

## CLASS 17: OPEN – Coloured Quartz

### 21.177 Solomon's Shield #2

Covill, Charles W; Unpublished 6 Oct 92  
Has unpolished rim facets.

#### Facet Data

Pavilion facets	56	Pavilion tiers	5
Girdle facets	8	Girdle tiers	1
Crown facets	48+1	Crown tiers	5+1
<b>Total facets</b>	<b>113</b>	<b>Total tiers</b>	<b>12</b>

#### Size Data

L/W	1.000	P/W	0.526
T/W	0.514	C/W	0.216
U/W	0.514	H/W	0.753
V/W <sup>3</sup>	0.286	P/C	2.438

#### Design Data

Angles for R.L.	1.54
Symmetry	8-fold, mirror
Index gear	96

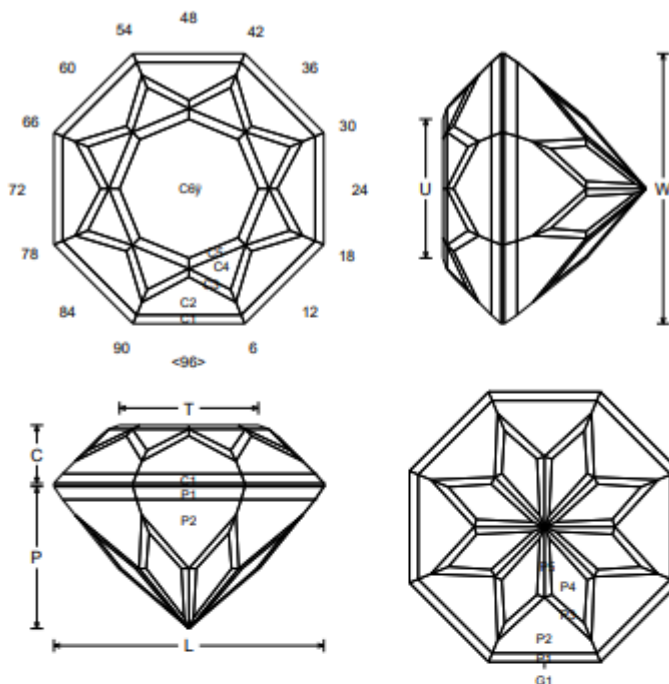

#### Pavilion

G1	90.00	96-12-24-36-48-60-72-84	
P1	56.00	96-12-24-36-48-60-72-84	
P2	51.00	96-12-24-36-48-60-72-84	
P3	43.60	05-07-17-19-29-31-41-43-53-55-65-67-77-79-89-91	Unpolished. Leave 1200 grit finish.
P4	42.60	06-18-30-42-54-66-78-90	
P5	42.00	05-07-17-19-29-31-41-43-53-55-65-67-77-79-89-91	Unpolished. Leave 1200 grit finish.

#### Crown

C1	48.00	96-12-24-36-48-60-72-84	
C2	45.00	96-12-24-36-48-60-72-84	
C3	39.00	02-10-14-22-26-34-38-46-50-58-62-70-74-82-86-94	Unpolished. Leave 1200 grit finish.
C4	31.00	06-18-30-42-54-66-78-90	
C5	22.00	06-18-30-42-54-66-78-90	Unpolished. Leave 1200 grit finish.
C6y	0.00	Table	



## CLASS 18: NOVICE – Coloured Quartz

### APHEX

USFG 2011 SSC Novice Stone  
By Jeff Ford

#### Facet Data

Pavilion facets	12	Pavilion tiers	2
Girdle facets	6	Girdle tiers	1
Crown facets	18	Crown tiers	3
<b>Total facets</b>	<b>36</b>	<b>Total tiers</b>	<b>6</b>

#### Size Data

L/W	1.155	P/W	0.520
T/W	0.000	C/W	0.230
U/W	0.000	H/W	0.799
V/W <sup>3</sup>	0.294	P/C	2.262

#### Design Data

Angles for R.I.	1.54
Symmetry	6-fold, mirror
Index gear	96

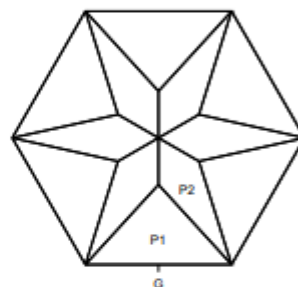
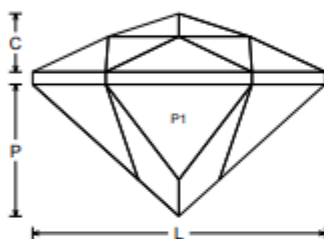
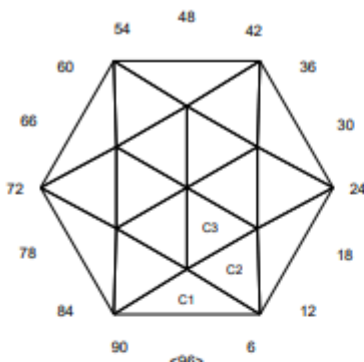

#### Pavilion

G	90.00	96-16-32-48-64-80
P1	50.00	96-16-32-48-64-80
P2	42.00	08-24-40-56-72-88

Set Stone size  
Cut TCP  
Cut PCP, Meet P1,G

#### Crown

C1	38.00	96-16-32-48-64-80
C2	25.00	08-24-40-56-72-88
C3	18.00	08-24-40-56-72-88

Set Girdle Width  
Meet C1, G  
Meet C1, C2

## Trophies & Cups

- **Presidents Cup** – MGLS members only  
Awarded for the highest scoring entry - Novice
- **The Memorial Trophy** (Previously the **Arthur Mullens Trophy**)– MGLS members only  
Two awards (Open and Novice) - Awarded for the highest scoring entry
- **Don Wilkinson Trophy**  
Awarded to the entry that scores the highest number of judging points for an individual freeform
- **Laurie & Val Saint Trophy**  
Award for the highest scoring entry (set piece) - Novice.
- **All that Glitters Cup**  
Award for the highest scoring entry (In Classes 19-24) - Open.
- **Open Facetors Trophy**  
Award for the highest scoring entry set piece - Open.
- **Novice Facetors Trophy**  
Award for the highest scoring entry set piece - Novice.
- **Fossicker’s Cup** – MGLS members only  
Awarded for the best entry found on a field trip (Judges Choice)  
Entries must be entered as found however entries can be partially slabbed but must not be worked.
- **Novice Show Champion**  
Highest aggregate score of entrant’s best 3 entries of the ‘NT’ trophy sections listed in this schedule.
- **Open Show Champion**  
Highest aggregate score of entrant’s best 4 entries of the ‘OT’ trophy sections listed in this schedule.
- **Junior Show Champion** – MGLS members only  
Highest aggregate score of entrant’s best 2 entries of the ‘JC’ trophy sections listed in this schedule.

**Notes for completing Competition Entry Form and submitting entries:**

- Complete details of your name, lapidary club and phone number at the top of the form.
- Write the class number you are entering in the “Class No.” column.
- If you are entering multiple entries in any class (maximum of two entries per class) then please repeat that class for each entry. No descriptions of pieces are required, only class numbers.
- Each entry must be wrapped in soft paper (eg. paper towel, toilet paper), and placed in a small zip- lock bag.
- Faceting entries must be presented in a gem box and have the name of the material on the box.
- As per Australia Post requirements, the packaging for sharp-edged or pointed items in the metalcraft classes must comprise:
  - o primary wrapping with the sharp edges or points wrapped in or protected by cork, polyurethane foam or similar material
  - o an outer rigid container of metal, wood, strong plastic or other rigid material.



**2025 COMPETITION ENTRY FORM**

Name ..... Club .....

Phone No. ....

Class Number	Office Use Only (Entry No.)

Class Number	Office Use Only (Entry No.)