MT GRAVATT LAPIDARY

SOCIETY INC

56th Annual Gem and Mineral Display 2024
SATURDAY 25th MAY 8.00 am - 4.00pm
AT OUR CLUBROOMS 1873 LOGAN RD UPPER MT. GRAVATT 4122

2024 SCHEDULE

NOTES AND CONDITIONS

Each entry will not be judged against its competitors but will be assessed against an established standard and the resulting score is the measurement of excellence achieved, or how nearly it reaches that standard.

Judging is to the AFLACA Competitor and Judging Manual for Lapidary and Allied Competitions Issue No.8 April 2015 (Manual), unless otherwise stated in this schedule. The competition committee will be using the guidelines as set out in the Competitor and Judging Manual except as stated in this schedule. A copy of the Manual is available in the library.

COMPETITION ENTRY IS FREE

Closing date for entries SECTIONS 1 TO 29 is 12pm on Saturday 6th April 2024.

Entries accepted at the clubrooms from 9am to 12pm or by arrangement with the Chief Steward. Entries sent via post should be received by Friday afternoon 5th April 2024. Late entries will be deemed ineligible but may be used for display purposes. If you need to send entries via post, we recommend these be sent at least two (2) weeks prior by express post to ensure entries are received by the due date.

Closing date for SECTIONS 30 to 39 is 7pm on Tuesday 21st May 2024.

Entries accepted at the clubrooms between 4pm – 7pm or by arrangement with the Chief Steward.

Postal entries should be sent by registered mail or express post to:

Chief Steward
PO Box 150
MT GRAVATT QLD 4122

PLEASE ENSURE YOU INCLUDE RETURN POSTAGE AND AN APPROPRIATELY SIZED ENVELOPE

- No change will be made to the schedule once approved.
- No late entries will be accepted.
- Entries can be collected from 4.15pm Saturday 25th May 2024. If you cannot collect your entries on show day, then you must make arrangements with the Chief Steward.
- This is a Level Two Competition. Interstate entries are welcomed. **OTHER CLUBS ARE WELCOME.**
- Entries not complying with conditions may be disqualified by Stewards or placed in the correct section. The Stewards have the right to refuse any entry.
- All possible care will be taken with entries, but the Committee will not be held responsible for loss or damage during transit, display or storage.
- An entry constitutes acceptance of conditions and agreement to comply with them.
- Unsportsmanlike conduct displayed before, during or after the competition may result in disqualification of the entry and the revocation of any awards given. Page 5 Competitor and Judging Manual No. 8 April 2015.
- Members of Mt Gravatt and are members of other clubs will be entered as Mt Gravatt Club members.

Variations to Competitor and Judging Manual

1. A pair of earrings or cufflinks are judged as one item (Jewellery Sections only)
2. **Limit of 2 (two) entries per person per class**
3. Showcase entry quantities vary from the manual
4. Man-made material can be used as specified in the schedule
5. Class Numbers do not correspond to the Section Numbers in the Competitor and Judging Manual
6. All Metalcraft with sharp or pointed elements must have all sharp/pointed edges padded and be presented in a rigid box ready for postage. This is a requirement of Australia Post and must be met so that entries can be sent for judging. Stewards can refuse entries if packaging requirements are not met.

ENQUIRIES: Email: Chief Steward via President (president@mglslapidary.com.au)

COMPETITION CLASSES

CS=Craftsmanship, AA=Aesthetic Appeal, Min=minimum, Max=maximum, J&R=Competitor and Judging Manual
 N=Novice, O=Open, NT=Novice Trophy, OT=Open Trophy, PC= President’s Cup, MC=Memorial Trophy, DW=Don
 Wilkinson Trophy, LS=Laurie & Val Saint Trophy; FT=Novice Facetors Cup

CABOCHONS (Groups 1 & 2)					
Unless specified, all entries can be no longer than 80mm on the longest axis and no shorter than 15mm on the longest axis					
Class	Level	J&R Section	Description	AA or CS	Trophy
PRESIDENTS CUP (Mt Gravatt Club Members Only)					
1	N	1A	Standard Cabochon – Agate	AA	PC, JC
The MEMORIAL TROPHY (Mt Gravatt Club Members Only)					
2	O	1B	Fancy Cabochon – set to Open template – Tiger Eye	CS	MC, JC
3	N	1B	Fancy Cabochon – set to Novice template – Tiger Eye	CS	MC, JC
The following are open to all					
4	O	1A	Standard Cabochon – any natural material	CS	OT, JC
5	N	1A	Standard Cabochon – any natural material	CS	NT, JC
6	O	1A	Standard Cabochon – Agate	AA	JC
7	O	1B	Fancy Cabochon – Petrified Wood	CS	JC
8	N	1B	Fancy Cabochon – Petrified Wood	CS	JC
9	O	1B	Fancy Cabochon – any natural material	AA	OT, JC
10	N	1B	Fancy Cabochon – any natural material	AA	NT, JC
11	O	2A	Double Standard Cabochon – any natural material	CS	OT, JC
12	N	2A	Double Standard Cabochon – any natural material	CS	NT, JC

FREEFORMS (Group 3)					
All entries maximum size 85mm on the longest axis, minimum 25mm on longest axis and must fit through a 40mm hole.					
Class	Level	J&R Section	Description	AA or CS	Trophy
13	O	3	Freeform – any natural material	AA	DW, JC
14	N	3	Freeform – any natural material	AA	DW, JC

FACET CUTS (Groups 8 – 11)					
All entries should be a minimum 6mm on the longest axis					
Class	Level	J&R Section	Description		Trophy
15	O	10	Modified Cut ‘Double Box Star’ – material - coloured Nanosital		OT
16	N	9A	Simple Emerald Cut – material - coloured Quartz		
17	O	10	Modified Cut ‘Trilliant C’ – material - Topaz		FT
18	N	10	Modified Cut – Square Barion cut – material - coloured Quartz		NT

HAND FABRICATED JEWELLERY (Group 18)					
Class	Level	J&R Section	Description		Trophy
19	O	18A	Jewellery Hand-Fabricated; not intended to include lapidary, fossil or mineral items		OT
20	N	18A	Jewellery Hand-Fabricated; not intended to include lapidary, fossil or mineral items		NT
21	O	18B	Jewellery Hand-Fabricated; lapidary cut and set by entrant		OT
22	N	18B	Jewellery Hand-Fabricated; lapidary cut and set by entrant		NT
23	O	18D	Jewellery Hand-Fabricated; commercial lapidary item/s set by entrant		
24	N	18D	Jewellery Hand-Fabricated; commercial lapidary item/s set by entrant		
25	O	18D	Jewellery Hand-Fabricated; Commercial Lapidary item/s set by entrant - Opal		
26	N	18D	Jewellery Hand-Fabricated; Commercial Lapidary item/s set by entrant – Tab Set Cabochon		LS

COMMERCIAL MOUNT JEWELLERY (Group 25)				
Class	Level	J&R Section	Description	Trophy
27	O	25	Commercial Mount Jewellery; with lapidary cut & set by entrant; material any natural cabochon; lapidary min 10mm on the longest Axis	OT
38	N	25	Commercial Mount Jewellery; with lapidary cut & set by entrant; material any natural cabochon; lapidary min 10mm on the longest Axis	NT

GENERAL METALCRAFT (Group 27)				
Class	Level	J&R Section	Description	Trophy
29	O	27A	General Metalcraft; not intended to included lapidary; Metalcraft is defined as items that are for general ornamentation and/or service, not jewellery; size to measure between 10mm to 170mm on the longest axis	

The Following Sections are to be delivered to the Club room in person on Tuesday 21st May 2024 between 4pm-8pm

POLISHED FACES (Group 13)					
All entries should be no longer than 120mm and no shorter than 40mm on any dimension					
Class	Level	J&R Section	Description	AA or CS	Trophy
30	O	13	Polished Face Flat Surface – any material	AA	

NOVELTY GEMCRAFT (Group 17)				
Entries must be accompanied by a label stating title and main materials (Label will not be judged)				
Class	Level	J&R Section	Description	Trophy
31	O	17	Novelty gemcraft; Material predominantly lapidary	
32	N	17	Novelty gemcraft; Material predominantly lapidary	

SHOWCASES (Group 30)				
<u>Please note – Showcase items must be labelled. See J&R manual page 88 for information</u>				
Class	Level	J&R Section	Description	Trophy
33	O	30A	Showcase; Solo; unlit; 9 cabochons and/or freeform stones; at least 3 different shapes and 4 different materials; may include man made material	
34	N	30A	Showcase; Solo; unlit; 5 cabochons and/or freeform stones; at least 3 different shapes and 4 different materials; may include man made material	
35	O	30A	Showcase; Solo; unlit; 7 pieces of handcrafted jewellery; at least one with and one without lapidary material; may include man made material	
36	N	30A	Showcase; Solo; unlit; 5 pieces of handcrafted jewellery; may include man made material	
37	O	30A	Showcase; Solo; unlit; 5 faceted stones in a small box; any shape or material; may include man made material	
38	N	30A	Showcase; Solo; unlit; 3 faceted stones in a small box; any shape or material; may include man made material	

Exhibitors please note that there are some showcases available for loan from the stewards

FOSSICKERS CUP (Mt Gravatt Club members only)				
This will be judged as a Judges Choice.				
Entries must be entered as found, however, entries can be partially slabbed but must not be worked				
Class	Level	J&R Section	Description	
39		n/a	Best entry found on a club field trip between 1 May 2023 and 30 April 2024	

SECTION 15: OPEN – Coloured Nanosital

Double Box Star

Converted to 96 Index - July 2023
 Adapted from a design by Fred W. Van Sant, Star Cuts I (1988) [PC 21.083A FVS-19]
 Released into the public domain in memory of Charles L. Moon

Facet Data

Pavilion facets	48	Pavilion tiers	4
Girdle facets	8	Girdle tiers	1
Crown facets	32+1	Crown tiers	3+1
Total facets	89	Total tiers	9

Size Data

L/W	1.000	P/W	0.490
T/W	0.571	C/W	0.189
U/W	0.571	H/W	0.697
V/W ³	0.266	P/C	2.598

Design Data

R.I. range	1.61 - 1.76
Symmetry	8-fold, mirror
Index gear	96
Shape	Octagon

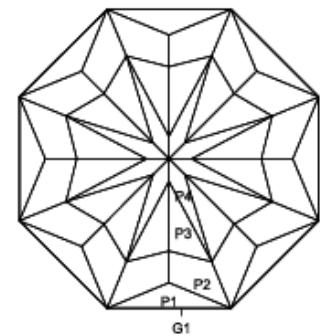
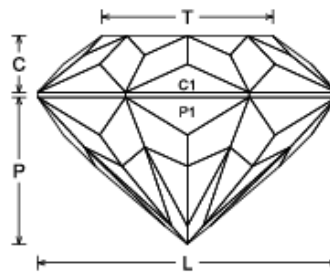
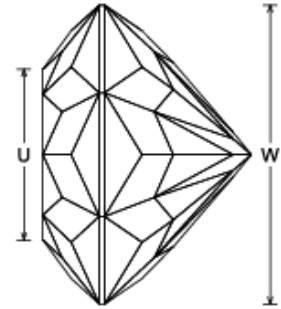
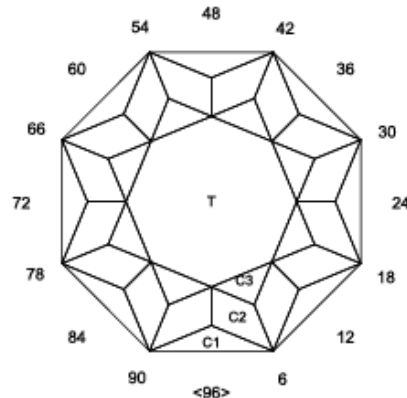

Pavilion

G1	90.0	96-12-24-36-48-60-72-84
P1	55.6	96-12-24-36-48-60-72-84
P2	45.2	03-09-15-21-27-33-39-45-51-57-63-69-75-81-87-93
P3	41.6	04-08-16-20-28-32-40-44-52-56-64-68-76-80-88-92
P4	41.0	06-18-30-42-54-66-78-90

Crown

C1	47.6	96-12-24-36-48-60-72-84
C2	37.0	03-09-15-21-27-33-39-45-51-57-63-69-75-81-87-93
C3	30.6	06-18-30-42-54-66-78-90
T	0.0	Table

SECTION 16: NOVICE – Quartz

Simple Emerald Cut

Facet Data

Pavilion facets	20	Pavilion tiers	8
Girdle facets	8	Girdle tiers	3
Crown facets	24+1	Crown tiers	9+1
Total facets	53	Total tiers	21

Size Data

L/W	1.144	P/W	0.569
T/W	0.714	C/W	0.191
U/W	0.569	H/W	0.822
V/W ³	0.461	P/C	2.978

Design Data

Angles for R.I.	1.54
Symmetry	2-fold, mirror
Index gear	96

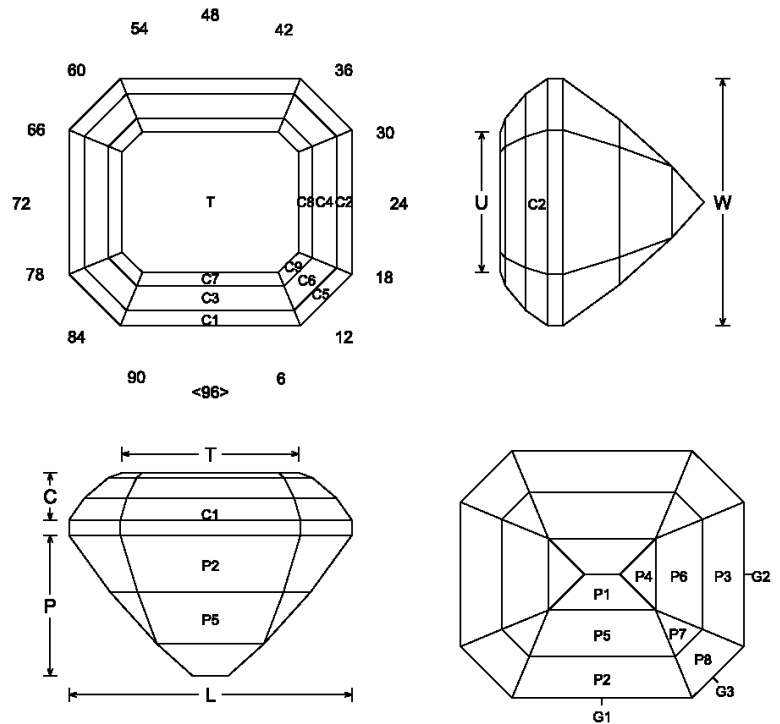

Pavilion

G1	90.0	96-48
G2	90.0	24-72
P1	42.0	96-48
P2	54.0	96-48
P3	54.0	24-72
P4	42.0	24-72
P5	48.0	96-48
P6	48.0	24-72
P7	48.0	12-36-60-84
P8	54.0	12-36-60-84
G3	90.0	12-36-60-84

Crown

C1	55.0	96-48
C2	55.0	24-72
C3	40.0	96-48
C4	40.0	24-72
C5	55.0	12-36-60-84
C6	40.0	12-36-60-84
C7	20.0	96-48
C8	20.0	24-72
C9	20.0	12-36-60-84
T	0.0	Table

SECTION 17: OPEN – Topaz

Trilliant C (13.067)

Watermeyer, Bazil/Steele, Norman - 1991
From Seattle Facetor Design, August 1991, Page 1

Facet Data

Pavilion facets	18	Pavilion tiers	3
Girdle facets	12	Girdle tiers	2
Crown facets	27+1	Crown tiers	5+1
Total facets	58	Total tiers	11

Size Data

L/W	1.001	P/W	0.385
T/W	0.578	C/W	0.127
U/W	0.555	H/W	0.532
V/W ³	0.162	P/C	3.032

Design Data

R.I. range	1.54 - 1.76
Symmetry	3-fold, mirror
Index gear	96
Shape	Triangle

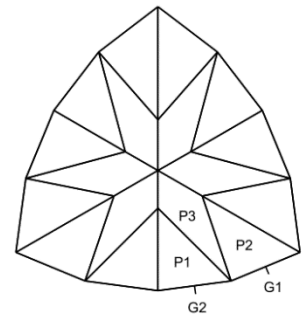
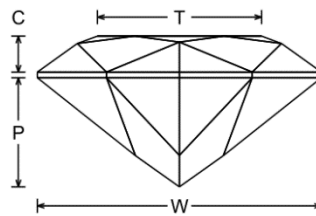
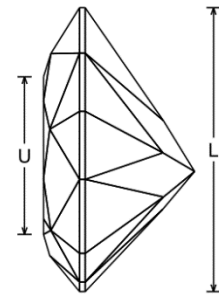
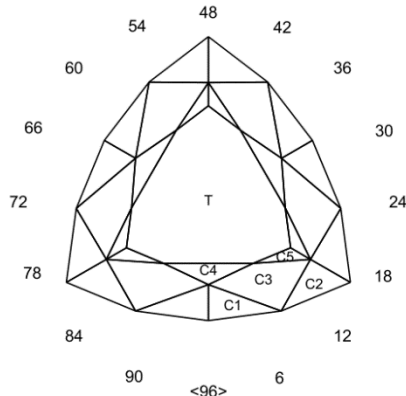

Pavilion

P1	43.5	02-30-34-62-66-94
P2	41.0	06-26-38-58-70-90
G1	90.0	06-26-38-58-70-90
G2	90.0	02-30-34-62-66-94
P3	41.0	04-28-36-60-68-92

Cut to temporary centre point (TCP)
Meet P1 at TCP
Fix size (width)
Level girdle
Meet P1-P2-G1-G2

Crown

C1	40.0	02-30-34-62-66-94
C2	38.0	06-26-38-58-70-90
C3	34.0	04-28-36-60-68-92
C4	16.0	96-32-64
C5	22.2	06-26-38-58-70-90
T	0.0	Table

Match pavilion facets at girdle
Level girdle
Meet C1-C2-G1-G2 at girdle
Meet C1-C1-C3
Meet C3-C2-C2-C3
Should meet all star facets

SECTION 18: NOVICE – Quartz

SQUARE REVERSE CUT CROWN - QUARTZ

Modified from a design by Evan A Williams
Barion type cut. Brilliance in a square.
ANGLES FOR QUARTZ

Facet Data

Pavilion facets	20	Pavilion tiers	2
Girdle facets	8	Girdle tiers	2
Crown facets	16+1	Crown tiers	3+1
Total facets	45	Total tiers	8

Size Data

L/W	1.000	P/W	0.531
T/W	0.577	C/W	0.212
U/W	0.577	H/W	0.763
V/W ³	0.331	P/C	2.510

Design Data

Angles for R.I.	1.54
Symmetry	4-fold, mirror
Index gear	96
Shape	Square

Comments

This design works well with light to medium colour gemstones (eg citrine, amethyst)
The angles given are for quartz and other gemstones with an RI of 1.54.

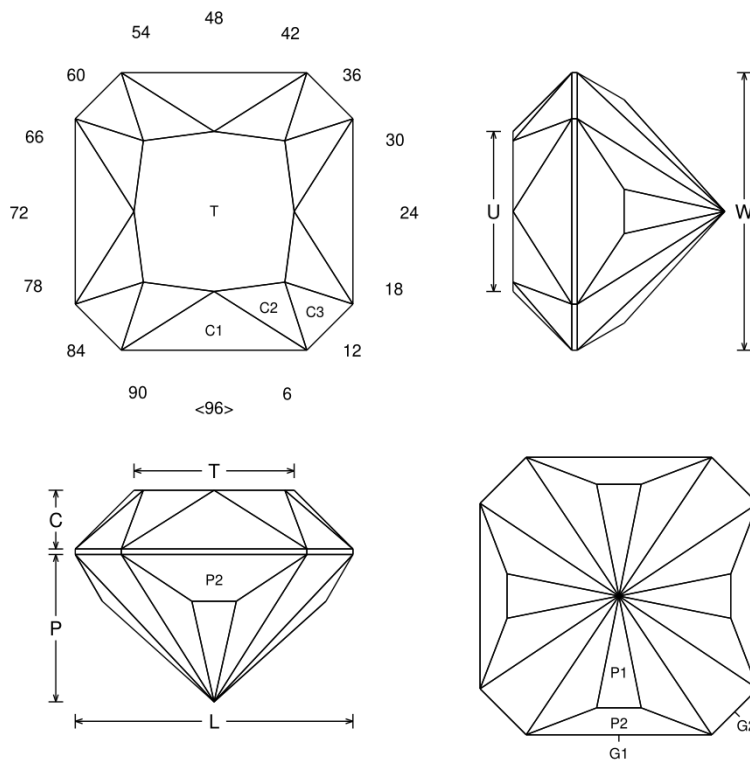

Pavilion

P1	42.00	96-06-12-18-24-30-36-42-48-54-60-66-72-78-84-90	Cut to FCP.
G1	90.00	96-24-48-72	Set size. Establish girdle.
G2	90.00	12-36-60-84	Establish girdle. Meet P1, G1.
P2	60.00	96-24-48-72	Meet P1, G1, G2.

Crown

C1	45.00	96-24-48-72	Match pavilion facets at girdle
C2	39.86	02-22-26-46-50-70-74-94	Cut to meet C1 at girdle
T	0.00	Table	Cut table. Meet C1.
C3	42.69	12-36-60-84	Cut to meet C1, C2, G1

Trophies & Cups

- **Presidents Cup** – MGLS members only
Awarded for the highest scoring entry - novice
- **The Memorial Trophy** (Previously the **Arthur Mullens**)– MGLS members only
Two Awards (Open and Novice) - Awarded for the highest scoring entry
- **Don Wilkinson Trophy**
Awarded to the entry that scores the highest number of judging points for an individual freeform
- **Laurie & Val Saint Trophy**
Award for the highest scoring entry (set piece) - novice.
- **Novice Facetors Trophy**
Award for the highest scoring entry set piece - novice.
- **Fossicker’s Cup** – MGLS members only
Awarded for the best entry found on a field trip (Judges Choice)
Entries must be entered as found however entries can be partially slabbed but must not be worked.
- **Novice Show Champion**
Highest aggregate score of entrant’s best entry in 3 of the sections listed in the schedule with NT listed.
- **Open Show Champion**
Highest aggregate score of entrant’s best entry in 4 of the sections listed in the schedule with OT listed.
- **Junior Show Champion** – MGLS members only
Highest aggregate score of entrant’s best 2 entries in a cabochon or freeform section (Groups 1 – 3).

Notes for completing Competition Entry Form and submitting entries:

- Complete details of your name, lapidary club and phone number at the top of the form.
 - Write the class number you are entering in the “Class No.” column.
 - If you are entering multiple entries in any class (maximum of two entries per class) then please repeat that class for each entry. No descriptions of pieces are required, only class numbers.
 - Each entry must be wrapped in soft paper (eg. paper towel, toilet paper), and placed in a small zip- lock bag.
 - Faceting entries must be presented in a gem box and have the name of the material on the box.
 - As per Australia Post requirements, the packaging for sharp-edged or pointed items in the metalcraft classes must comprise:
 - primary wrapping with the sharp edges or points wrapped in or protected by cork, polyurethane foam or similar material
 - an outer rigid container of metal, wood, strong plastic or other rigid material.
-



2024 COMPETITION ENTRY FORM

Name Club

Phone No.

Class Number	Office Use Only (Entry No.)

Class Number	Office Use Only (Entry No.)